

## B1100-GP

General Purpose Controller with RS232, RS485, CANopen and DeviceNet interfaces.

The series B1100-GP General Purpose Controller combines the functions of the B1100-PP and E1100-VF controllers, with the additional capability of serial communication with a master controller.

Motions can be prescribed via RS232, RS485, CANopen and DeviceNet, using positions, velocity, acceleration, and maximum force. In streaming mode, travel profiles that are stored in the master controller can be transferred to the controller via cyclical target values.

Serial communication can also be used to access all internal parameters.

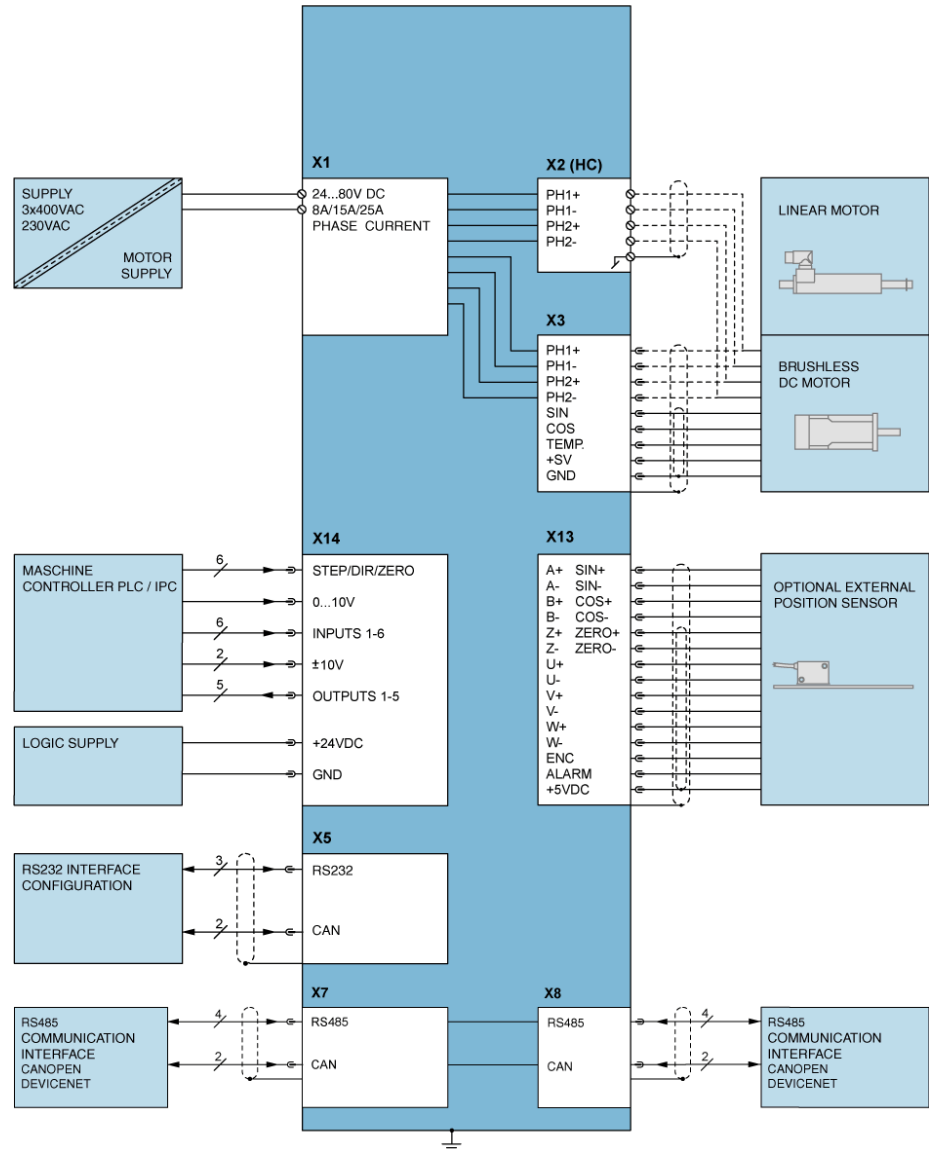
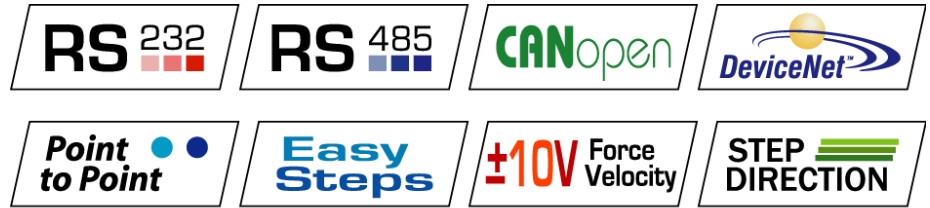

Item	Description	Part Number
B1100-GP	General Purpose Controller (72V/8A)	0150-1737
B1100- GP -HC	General Purpose Controller (72V/15A)	0150-1738
B1100- GP -XC	General Purpose Controller (72V/25A)	0150-1741